

Analysis of anxiety-induced factors during Computer-Based Examination among Undergraduates in a Nigerian University: a case study

¹Shittu, Ahmed Tajudeen (PhD) ¹Jebson, Sofeme Reuben (PhD) ²Bello, Rabi (PhD) ²Kareem, W. B. (PhD)

¹Department of Science Education Federal University of Kashere, Gombe State

²Department of Science Education /Department of Industrial and Technology Education
Federal University of Technology Minna, Niger State

Abstract

The study explored factors that could induce anxiety during a computer based examination among first year students in a Nigerian university. The study employed survey research method with 369 participants purposively selected as sample of the study. The instrument used for gathering the data was tagged (Anxiety Induced by Computer Based Examination Questionnaire). It was adapted and modified for the purpose of the study. The data gathered was subjected to factor analysis and Structural Equation Modeling (SEM) analysis with AMOS statistical software. For extraction, the data was subjected to Principal Component Analysis (PCA) with direct oblmin. Factor with eigenvalue > 1 were extracted and three factors were realized. Out of 28 items used in the instrument, 16 items were observed to load on the three factors extracted. . The internal consistence of the factor was computed and each factor was greater than 0.7 alpha values. The total variance explained was 59.50%, Kaiser-Meyer-Olkin measure of Sampling Adequacy (KMO) was 0.88 greater than 0.6 required threshold. The extracted factors are (Techno-induced anxiety), which contained 4 items, (Human-induced anxiety) contained 3 items and (Exam-induced anxiety) contained 8 items. The correlation analysis with AMOS showed an existence of causal relationship among the three factors. The study has validated and provided empirical support for the existence of 3 factors interplay to induce anxiety of students exposed to computer based examination. The finding has uncovered some of the causes of students' anxiety when they are subjected to computer-based examinations.

Keyword: Exploratory Analysis, Computer-Based Test, Techno-induced Anxiety, Exam- Induced anxiety and Human-induced anxiety

Introduction

The rate with which students are withdrawn on account of poor academic performance from the university after their first year examination has become a source of serious concern to stakeholders in Nigerian educational system. Specifically, almost five hundred (500) first year students of a federal university located in North Central and South Western Nigeria were withdrawn in 2016/17 academic session due to their low academic performance (Adesina, 2017; Punch, 5, 2017). The most surprising of it is that these students were subjected to series of screening before being selected for admission because the number of qualify candidate outnumber the available space. This informs the careful selection process and yet, the few

selected could not defend the admission offered to them at the expense of many other qualified candidates. The failure rate of students has hitherto generated some pertinent questions such as what are the underline causes to the poor academic performance among the first year students? Why do majority of them find it difficult to proceed beyond 100 level? Due to the painstaking processes of selection, those eventually chosen were assumed to possess the potential for university education. Though empirical evidence has revealed causes of poor academic performance among the university students which include: poor methodology of teaching, Cognitive, psychological and emotional state of students writing a test or an examination (Falode, Gambari, Shittu Gimba,

Falode and Awoyemi, 2015). More importantly, the factors that lead to students' underperformance in examinations are attributed to test anxiety which reside in the emotional, behavioural and physiological state of test takers (Wong, 2008), thus contributing significantly to restlessness and forgetfulness which in turn impede student's performance in examination (Hagtvet & Benson, 1998).

Given the empirical evidence to the strength of anxiety as a significant factor contributing to students' failure rate and lack of studies to verify other sources or what could trigger or induce anxiety among students exposed to computer-based test is the reason for this study.. The study, therefore, set out to unravel the underlying dimension of factors that could induce anxiety among students subjected to computer based examination in a Nigerian university based on the existing sentiment that computer based test could heighten anxiety (Power, 1999).

Literature Review

The process of administering test and examination for measuring students' academic performance has witness tremendous improvement in the contemporary educational system. The advent of information and communication technology has brought a paradigm shift to the method of assessing students' academic performance which invariably provides a means of determining what the students have achieved based on the predetermined intended learning outcome. Though computer-based test (CBT) has been in use since 1960s and has been identified as a good alternative to paper and penci- based test (PPT) (Jimoh, Shittu, & Kawu 2012). Evidence from literature shows that CBT has many advantages over paper and pencil test (PPT). Among these advantages, as stated by Balogun and Olanrewaju (2016), were that CBT provides easy administration, flexibility in time and space, prompt scoring of test result and cost effective in test production compared with PPT. It also reduces misconduct during examination and that it is more secure and most effective and accepted means of assessment the world over (Cantillon, Irish & Salos, 2004; Ogunmakin & Osakuade, 2014).

However, empirical evidence from studies also showed some disadvantages of CBT: reading from the screen of a computer was 20% to 30% slower than reading from a question paper (Buzzetto-More, Sweet-Guy, & Elobaid, 2007; Mahmoodi & Esfandiary, 2016). Another study on CBT also showed that using computer was more time-consuming. However, it provides rich graphical and dynamic texts for the students (Bugbee, 2014; Mahmoodi & Esfandiary, 2016). Despite the limitations and advantages of CBT, shifting from PPT to CBT may affect psychometric features of a test when linking it to speed and difficulty. In the Nigerian university system, computer has become a major tool for evaluating student's academic performance. Aside the novelty of CBT, the incessant increase in student enrolment make conventional PPT a cumbersome means of evaluating students' performance, hence, the shifting to the use of automated testing system with computer (Jimoh *et al*, 2016).

Since the introduction of CBT, its effectiveness has attracted educational researchers attention, studies on the effectiveness of CBT compare to PPT showed that CBT is more effective but at the same time the attention of CBT users need to be drawn to an important factor which was not given the desire consideration and yet contribute to dismal academic performance of students and the reason could be located in anxiety induced by CBT (Watson, 2001)

In the recent time, students' academic performance is falling at a rate that calls for concern. Many factors have been attributed to this. The most notable factor may reside in test anxiety during examination. Carr (2016) posited that a student with high degree of anxiety may likely perform woefully in an examination. Similarly, Winerip (1993), asserted that the environment where testing is conducted may also contribute to test anxiety. In fact, the test takers may feel less stressed in smaller computer-based test setting than in large hall. Sarason (1987) and Dusek (1980) attributed worry and emotional reaction as causes of anxiety. To Benjamin, McKeachie, Lin, and Holinger (1981), anxiety does not only produce poor performance but poor ability can also create anxiety. To Liebert and Morris (1967),

test anxiety was not just symptom of general anxiety but includes factors related to worry and emotions associated with testing situation. The concern of the present study therefore is to analyse anxiety-induced associated to computer-based examination among undergraduates in a Nigerian university by verifying the underling dimension of sources of anxiety in a computer based test.

Objectives of the Study

The main objective of this study is to explore the dimensionality of factors relating to computer induce anxiety among first year students in a Nigerian university. The second objective is to ascertain if correlation exists among the factors extracted and to ascertain the strength and direction of correlation.

Methodology

The study employed survey research method since it is the most appropriate method for non-experimental research. The sample of the study consisted of 369 first year students who volunteered to complete the administered research instrument used for eliciting the information required for the study. The number of male students used was 234 representing 63.3%, while the female students were 135 representing 36.7%. The respondents were drawn from all the faculties and schools of the university (see graphical illustration below):

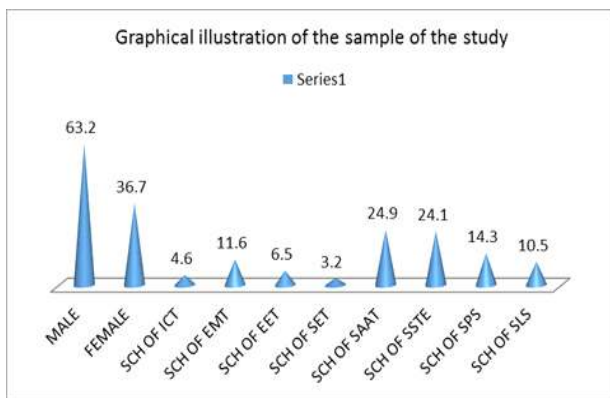

Figure 1: Graphical Illustration of the Sample of the Study

Research Instrument

The instrument tagged (Anxiety Induced by Computer Based Examination Questionnaire) was adapted and used for data collection. The instrument consisted of eight (8) Test Anxiety Inventory (TAI) developed by Spielberger

(1980) and fifteen (15) items extracted from a focus group discussion. The instrument was divided into sections A and B. Section A requested for demographic information of the respondents, while section B consisted of 23 items measured with 5 Likert scale with options of Not True (NT); Seldom True (ST); Moderately True (MT); Usually True (UT) and Always True (AT) respectively.

The instrument was later subjected to series of analysis especially content validation was done by four experts; all the observations raised was addressed before the final administration of the instrument to the respondents.

Data Collection and Analysis

The instrument was administered to the respondents directly by the researcher after every computer-based test conducted in second semester of year 2017. Four hundred (400) questionnaires were prepared and distributed, but 369 were found useful for the study, representing 92.25% return rate. To extract the underlying structure of computer-induced anxiety, the data was subjected to exploratory factor analysis using Direct Oblimin rather than Varimax rotation for extraction. Exploratory factor analysis was computed to ascertain evidence of unidimensionality of the component extracted (Elkatesh, Wong, & Fung, 2016).

Further analysis revealed evidence of sampling adequacy. The Kaiser Meyer Olkin (KMO) measure showed a value of 0.88 which is above the recommended threshold of 0.7 (Nunnaly, 1978), indicating that the sample is adequate. A check on the Bartlett's test of sphericity was significant with the value $\chi^2 = 2.715$, $df = .378$, $P = .000$ indicating that the correlation matrix is adequate hence, justifying the use of principal component analysis.

KMO and Bartlett's Test

Kaiser-Meyer-Olkin Measure of Sampling Adequacy.		.880
Bartlett's Test of Sphericity	Approx. Chi -Square	2.715
	df	378
	Sig.	.000

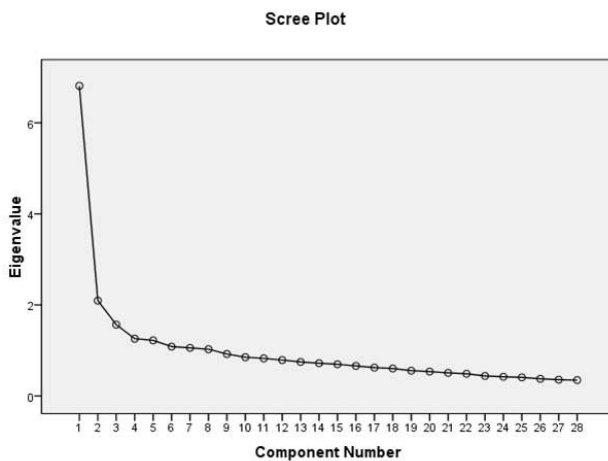

The Scree plot drawn from the data suggested three underlying factors structure explaining computer-induced anxiety. The Eigen value and the total variance explained the 3 factors and all the factors were adequately supported. The Eigenvalue criteria which are greater than 1.0 was evaluated and the result showed the existence of these factors, which altogether explained 59.50% of the total variance.

The 23 items used in the study were reduced to 16 items that were later found to form the three factors extracted for the study. The first factor extracted comprised of three items (5,6,7) *The stress we were subjected to before writing E-exam is too much; I do feel threatened during*

*electronic examination; Sometimes the time allocated for E-exam is not sufficient; These three items converged to explain the 'Human Induce Anxiety', the second factor extracted comprised of four items (11, 12, 13, 14) *Login problem arose my anxiety level during E-exam; Slow connection aggravated my anxiety during E-exam; Using computer for examination always scares me; Unfriendly condition could trigger anxiety during E-exam.* The four items converged to explain 'Techno induce Anxiety' and the third factor extracted comprised of eight items (21, 22, 23, 24, 25, 26, 27, 28):*The closer I am to a major E-exam, the harder it is for me to concentrate on the material; When I study, I worry that I will not remember the material on the E-exam day; During important E-exams, I think that I am doing awful or that I may fail; I lose focus on important E-exams, and I cannot remember material that I knew; I finally remember the answer to E-exam questions after the exam is already over; I worry so much before a major E-exam that I am too worn-out to do my best on the exam; I do not really feel myself when I take important E-exam; I find that my mind sometimes wander when I am taking E-exam; After doing E-exam, I worry about whether I did well enough.* The eight items converged to explain 'Induced Anxiety'.*

	q5	q6	q7	q11	q12	q13	q14	q22	q23	q24	q25	q26	q27	q28
q5	1.00													
q6	.451**	1.00												
q7	.390**	.455**	1.00											
q11	.188**	.180**	.121*	1.00										
q12	.155**	.211**	.152**	.486**	1.00									
q13	.188**	.188**	.160**	.328**	.419**	1.00								
q14	.162**	.204**	.073	.322**	.344**	.417**	1.00							
q22	.216**	.348**	.201**	.177**	.101	.194**	.206**	1.00						
q23	.235**	.311**	.394**	.214**	.209**	.159**	.146**	.348**	1.00					
q24	.218**	.270**	.186**	.169**	.154**	.158**	.212**	.315**	.305**	1.00				
q25	.256**	.303**	.299**	.178**	.231**	.217**	.184**	.386**	.420**	.400**	1.00			
q26	.215**	.268**	.311**	.171**	.189**	.211**	.120*	.376**	.434**	.291**	.512**	1.00		
q27	.258**	.226**	.308**	.232**	.237**	.232**	.249**	.313**	.315**	.361**	.494**	.515**	1.00	
q28	.213**	.192**	.183**	.225**	.251**	.281**	.294**	.316**	.191**	.371**	.360**	.372**	.483**	1.00
Comm:	.544	.637	.612	.519	.593	.527	.502	.388	.435	.395	.583	.580	.516	

Table 1: Inter-item Correlation Matrix of the Data

The correlations among the items were checked and found to be significant. The communality computed indicated to be between the ranges of .388 to .637. Table 1 shows the inter-item correlation and the communalities of the items. Furthermore, the factor loading on all the three factors ranges from 0.524 to 0.710, the finding provided empirical evidence on the strength of each indicator in the universe of construct they are required to represent. Furthermore, the internal consistency of the factors was computed with Cronbach Alpha coefficient. The

finding indicated existence of good internal consistency (Hair, Anderson, Tatham, & Black, 1998; Nunnally, 1978). The first factor showed a coefficient of .70, the second factor showed a coefficient of .72, while the third factor showed a coefficient of .83 alpha values.

Table 2: Component Analysis of the Underlying Structure of the Three Factors, Eigen Value, Variance Explained, and Cronbach Alpha

COMPONENTS						
Items	Comp 1	Comp 2	Comp3	Eigen Value	Variance Explained	Cronbach Alpha
Q 5	.609					
Q 6	.651					
Q 7	.616			23.86	24.33%	.70
Q 11		.593				
Q 12		.616				
Q13		.602				
Q14		.651		7.82	31.81%	.71
Q20			.592			
Q21			.563			
Q22			.622			
Q23			.637			
Q24			.524			
Q25			.703			
Q26			.710			
Q27			.693			
Q28			.572	5.82	37.40%	.83

To increase the critical mass of the study, the extracted factors were subjected to multivariate analysis using Structural Equation Modelling with Analysis of Moment Structure (AMOS) version 21 to further understand and evaluate the correlation that exists among these three variables. The result of the correlation analysis presented in figure 2, shows how related the factors are. The following fit indices were observed, they include p-value; Degree of freedom (Df); Root Mean Square error of Approximation (RMSEA); Tucker Lewis Index (TLI) and Comparative Fit Index (CFI). According to Hair et al (1998), Tucker Lewis Index (TLI) and Comparative Fit Index (CFI) are at a best fit if the value is above 0.90, while the recommended value for RMSEA is (< 0.8). A check on the graphical out-put of the fit indices showed an acceptable parameter because the confirmatory model figure 2 indicated a good measurement estimate with the data of the study (Hair et al. 1998).

Given the result of the graphical out-put, the casual relationship was observed on the factors. The relationship showed a statistical significant correlation coefficient with total variance explained of 0.54 for Exam induce anxiety; 0.71 on Human induce anxiety and 0.90 on Techno Induce anxiety. The finding further showed a positive significant correlation on Exam Techno with a coefficient value of (0.43, P < 0.005) which was significant; the effect recorded is a medium correlation based on

Cohen (1988) criteria. Exam Human with a coefficient value of (0.31, P < 0.005) was significant; and Human Techno showed a coefficient value of (0.32, P < 0.005), the relationship exhibited a slight, not too strong correlation compared to Exam Techno.

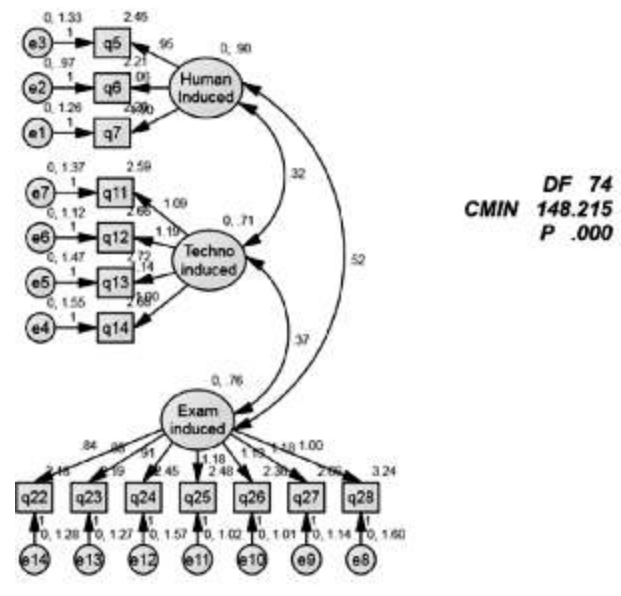

Figure 2: The Correlation Analysis of the Three Factors

Discussion and Conclusion

The study explored factors that can induce anxiety among first year students exposed to computer-based examination (CBT). The result of the study produced three underlying structure which is located in Human induced, Exam induced and Techno induced anxiety. The finding of the study provides empirical evidence to factors that cause or impair performance of students exposed to computer based examination. The finding of the study seems plausible because it showed that test anxiety and computer anxiety could play a joint role to impair students' performance on computer based test. This is evidence in 0.71 of the total variance explained on Techno induce anxiety as shown in the analysis. The finding of the study is also important because it provided the correlation that exists among the factors established in the study. The result showed that there are factors that can trigger as well increase level of students' anxiety which in-turn may lead to abysmal performance. The finding agrees

with Carr's (2016) assertion that a student with high degree of anxiety may probably not do well in an examination. The study also revealed that Human-induced anxiety is significant in computer based test with a total variance explained of 0.90, the finding supported Winerip (1993) conclusion that environment of test taker could trigger anxiety and that students that write a test in a smaller compute- based setting feel less anxiety than those in a big computer hall. The finding of the study has brought to fore the interplay of Exam, Techno and Human-induced anxiety as likely sources or factors of anxiety.

The empirical findings showed that students' performance is hampered when they are subjected to computer-based test. Therefore, the advantages of using the medium is eroded and the students are at the most affected when their anxiety levels are triggered.

Recommendations

- Since it is empirically established that computer-based test impaired students' performance, the university should therefore consider using paper and pencil test for continuous assessment purpose and CBT for the main examination.
- All bottlenecks associated with computer based examination should be addressed so as to reduce anxiety among the students.

References

- Adesina, A. (2017) Five hundred and ten first year UI students face withdrawal from school. PM Newspaper, Published on October 20, 2017. Retrieved from <https://www.pmnewsnigeria.com/2017/co/580-first-year-ui-students-face-withdrawal>
- Balogun, A. G., & Olanrewaju, A. S. (2016). Role of computer self-efficacy and gender in computer based test anxiety among undergraduates in Nigeria. *Psychological Thought*, 9(11), 58-66
- Benjamin, M., Mckeache, W. J., Lin, Y. G. & Holinger, D. P. (1981). Test anxiety: Deficit in information processing. *Journal of Educational Psychology*, 73, 816-824
- Bugbee, A. C. (2014). The equivalence of paper and pencil and computer based testing. *Journal of Research in Computing Education*, 28 (3), 82-99
- Buzzetto-More, N., Sweat-Guy, R., Elobad, M. (2007) Reading in a digital age: E-books are students ready for this learning objective, *International Journal of Electronic Learning*, 3 (1), 39-50
- Cantillion, P., Irish, B., & Salos, D. (2004). Using computer for assessment in medicine. *British Medical Journal*, 329, 606-609 doi:10.1136/bny.329.7466.606
- Carr, A. M. (2016). An exploratory study of test anxiety as relates to the national clinical mental health counseling examination, *Published These of University of South Florida*
- Cohen, J. (1988). *Statistical power analysis for the behavioural science*. (Second Edition) Hillsdale NJ. Lawrence
- Dusek, J. B. (1980). The development of test anxiety in children. In I. G. Sarason (Ed). *Test anxiety theory, research and applications* (pp. 87-119) Hilldale, NJ: Lawrence Erlbaum Associate
- Elkatesh, A. M., Wong, K. W., & Fung, C. C. (2016). Percieved ease of use and perceived usefulness of social for e-learning in Libyan higher education: A structural equation modeling analysis. *International Journal of Information and Education Technology*, 6 (3), 192-199
- Falode, O. C., Gambari, A. I., Shittu A. T., Gimba, R.W., Falode, W. E., & Awoyemi, D (2015). Effectiveness of virtual classroom in teaching and learning of senior secondary school mathematics concepts in Minna, Nigeria. *Indo-African Journal of Educational Research*, 3 (4), 01-04. Available Online : http://layer_rstpublisher.com
- Hagtvet, K. A., & Benson, J. (1998). The motive to avoid failure and test anxiety responses: empirical support for integration of two research traditions. *Anxiety, Stress & Coping*, 10(1), 35-57

- Hair, J., Anderson, R., Tathan, R., & Black, W. (1998). *Multivariate data analysis with reading*, England Cliffs, NJ: Prentice Hall.
- Jimoh, R. G., Shittu, A. K., & Kawu, Y. K. (2012). Student perception of computer based test (CBT) for examining undergraduate chemistry courses. *Journal of Emerging Trend in Computing and Information Science*, 3 (2), 1-10
- Liebert, R. M., & Morris, L. W. (1967). Cognitive and emotional components of test anxiety: A distinction and some initial data. *Psychological Reports*, 20 (3), 975-978
- Mahmoodi, F., & Esfandiary, R. (2016). An exploratory investigation into factors contributing to computer based testing. *Interdisciplinary Journal of Virtual Learning in Medical Science*, 7 (4), 1-8
- Nunnally, J. C. (1978). *Psychometric theory*, 2nd (Ed) New York: McGraw-Hill
- Ogunmakin, A. O., & Osakuade, J. O. (2014). Computer anxiety and computer knowledge as determinants of candidate performance in computer based test in Nigeria. *British Journal of Education, Society & Behavioural Science*. 4 (4), 495-507
- Power, D. E. (1999). *Test anxiety and test performance comparing paper based and computer adaptive versions of the GRE general test*. Educational Testing Service, Princeton New Jersey
- Punch Newspaper (2017) FUT Minna expels seven hundred students. Retrieved from <https://punch.ng.com/fut-minna-expels-700-students>
- Sarason, I. G. (1987). Test anxiety, cognitive interference, and performance. In R. E. Snow, & M. J. Farr (Eds) *Aptitude, learning and Instruction: vol.3 Cognitive and affective process analysis* (pp131-142) Hillsdale, NJ Lawrence Erlbaum
- Sarason, I. G. (1984). *Test anxiety: Theory, research & applications*. Hilldale, NJ: Lawrence Erlbaum Associates
- Watson, B. (2001). Key factors affecting conceptual gains from computer assisted instruction materials. *British Journal of Education*, 32 (5), 87-93
- Wong, S. S. (2008). The relations of cognitive trial, dysfunctional attitudes, automatic thought and irrational beliefs with test anxiety. *Current Psychology*, 27 (3), 177-191